

10



Europäisches Patentamt  
European Patent Office  
Office européen des brevets

11 Publication number:

**0 120 515  
B1**

12

**EUROPEAN PATENT SPECIFICATION**

13 Date of publication of patent specification: 22.11.90

14 Application number: 84200238.8

15 Date of filing: 21.02.84

16 Int. Cl.<sup>5</sup>: C 12 N 15/82, A 01 H 1/00,  
C 12 N 5/00, C 12 P 1/00 //  
(C12P1/00,  
C12R1:91),(C12N5/00,  
C12R1:91)

17 A process for the incorporation of foreign DNA into the genome of dicotyledonous plants; a process for the production of Agrobacterium tumefaciens bacteria.

18 Priority: 24.02.83 NL 8300699

19 Date of publication of application:  
03.10.84 Bulletin 84/40

20 Publication of the grant of the patent:  
22.11.90 Bulletin 90/47

21 Designated Contracting States:  
AT BE CH DE FR GB IT LI LU NL SE

22 References cited:  
MOLECULAR GENETICS OF THE  
BACTERIAPLANT INTERACTION, edited by  
A.Pühler, Springer-Verlag, Berlin (DE) 1983;  
SYMPOSIUM HELD IN GERMANY, AT THE  
UNIVERSITY OF BIELEFELD, Autumn 1982, pp.  
223, 228. J. HILLE et al.: "Onc-and vir-Genes  
located on the Ti-Plasmid of agrobacterium  
tumefaciens"

The file contains technical information  
submitted after the application was filed and  
not included in this specification

23 Proprietor: RIJKSUNIVERSITEIT LEIDEN  
Stationsweg 46 P.O. Box 9500  
NL-2300 RA Leiden (NL)

24 Proprietor: Schilperoort, Robbert Adriaan, Prof.  
Dr.  
Anthonie Duycklaan 10c  
NL-2334 CD Leiden (NL)

25 Inventor: Schilperoort, Robbert A., Prof. Dr.  
Anthonie Duycklaan 10c  
NL-2334 CD Leiden (NL)  
Inventor: Hille, Jacques, Dr.  
Reymerweg 76  
NL-8671 HG Renkum (NL)

26 Representative: Kooy, Leendert Willem et al  
OCTROOIBUREAU VRIESENDORP & GADE  
P.O. Box 266  
NL-2501 AW The Hague (NL)

27 References cited:  
PLASMID, vol. 7, 1982, pp. 107-118. J.HILLE et  
al.: "Construction and application of R Prime  
Plasmids, carrying different segments of an  
Octopine Ti Plasmid from Agrobacterium  
tumefaciens, for complementation of vir Genes"

Note: Within nine months from the publication of the mention of the grant of the European patent, any person may give notice to the European Patent Office of opposition to the European patent granted. Notice of opposition shall be filed in a written reasoned statement. It shall not be deemed to have been filed until the opposition fee has been paid. (Art. 99(1) European patent convention).

**EP 0 120 515 B1**

**EP 0 120 515 B1**

⑤ References cited:  
**JOURNAL OF BACTERIOLOGY**, v. 1. 154, no. 2,  
May 1983, pp. 693-701; J. HILLE et al.: "Site-  
directed Mutagenesis in *Escherichia coli* of a  
stable R772: Ti cointegrate Plasmid from  
*Agrobacterium tumefaciens*"

Advances in Gene Technology: **MOLECULAR  
GENETICS OF PLANTS AND ANIMALS**; ed. by K.  
Downey et al, Academic Press N.Y., 1983, pp.  
159-170

**Description**

A process for the incorporation of foreign DNA into the genome of dicotyledonous plants; a process for the production of *Agrobacterium tumefaciens* bacteria; stable cointegrate plasmids; plants and plant cells with modified genetic properties; a process for the preparation of chemical and/or pharmaceutical products.

The invention relates to a process for the incorporation of foreign DNA into the genome of dicotyledonous plants by infecting the plants or incubating plant protoplasts with *Agrobacterium tumefaciens* bacteria, which contain one or more Ti-(tumour inducing) plasmids.

It is known that the Ti plasmid of *A. tumefaciens* is essential for the capacity of this bacterium to cause the formation of tumours that are called "Crown gall" on dicotyledonous plants (Van Larebeke et al, Nature (London) 252, 169—170 (1974); Watson et al, J. Bacteriol. 123, 255—264 (1975); Zaenen et al, J. Mol. Biol. 86, 109—127 (1974). Part of this plasmid, designated as the T-region is integrated as T-DNA in the plant genome during tumour induction (the chromosomal DNA) (Chilton et al, Cell 11,263—271 (1977); Chilton et al, Proc. Nat. Acad. Sci. U.S.A. 77, 4060—4064 (1980); Thomashow et al, Proc. Nat. Acad. Sci. U.S.A. 77, 6448—6452 (1980); Willmitzer et al, Nature (London) 287, 359—361 (1980) and is expressed in various RNA-transcripts (Drummond et al, Nature (London) 269, 535—536 (1977); Ledebøer, thesis University of Leyden (78); Gurley et al, Proc. Nat. Acad. Sci. U.S.A. 2828—2832 (1979); Willimitzer et al, Mol. Gen. Genet. 182, 255—262 (1981)). The tumour cells show a phytohormone independent growth and contain one or more unusual aminoacid derivatives, known as opines, of which octopine and nopaline are best-known. The T-region of an octopine Ti plasmid carries a gene, which codes for the enzyme lysopine dehydrogenase (LpDH) or octopine synthase (OCS) which is responsible for the synthesis of octopine (Schröder et al, FEBS Lett. 129, 166—168 (1981)). The Ti plasmid furthermore contains genes for the catabolism of these opines by the bacterium (Bomhoff et al, Mol. Gen. Genet. 145, 177—81 (1976); Montoya et al, J. Bacteriol. 129, 101—107 (1977). If the T-region on the plasmid is lacking, no tumours are induced (Koekman et al, Plasmid 2, 347—357 (1979)). In addition to the T-region another region on the Ti plasmid appears to be essential for the tumour inducing capacity of the bacterium (Garfinkel et al, J. Bacteriol. 144, 732—743 (1980); Ooms et al, J. Bacteriol. 144, 82—91 (1980)), which part, however, has never been found in the plant tumour cells. This region with a size of about 20 Md, in which mutations appear to be complementary *in trans*, is called the *vir*-(virulence)-region (Hille et al, Plasmid 6, 151—154 (1981); Hille et al, Plasmid 7, 107—118 (1982); Klee et al, J. Bacteriol. 150, 327—331 (1982)).

It will be clear from the above that the procaryotic bacterium *A. tumefaciens* has a system for genetic manipulations of eucaryotic plants present in nature. The T-DNA-region of the Ti plasmid appears to be suitable for the incorporation of foreign DNA, in particular genes which code for particular desirable properties, into the genome of plant cells, the more so as in principle it is possible to eliminate the genes which are the cause of the tumour without simultaneously blocking the incorporation of the new genes. A first possibility seems to be to transform plant cells by infecting plants with *A. tumefaciens* bacteria which contain one or more Ti plasmids, the T-region of which is manipulated in the desirable manner. It is even better to incubate plant protoplasts with such *A. tumefaciens* bacteria.

For practical reasons the introduction of new genes in the T-region by means of recombinant-DNA techniques are preferably carried out in *Escherichia coli*. However, the Ti plasmid normally cannot be maintained in *E. coli* (it does not replicate in this host). So, in the existing procedures a so-called shuttle vector is used which replicates in *E. coli* and *A. tumefaciens* and into which the T-region is introduced. Subsequently new genes are introduced into this T-region. However, the complete Ti plasmid is necessary in order to transform cells via *A. tumefaciens*. The reason is that the Ti plasmid contains the essential *vir*-region on which genes are positioned which see to the processing of T-DNA (presumably by recognition of base sequences at the extremities of this T-region) and the transfer to the plant.

Since the Ti plasmid does not replicate in *E. coli* in the existing procedures, the shuttle vector with the manipulated T-region is transferred to an *A. tumefaciens* which contain a complete Ti plasmid which can co-exist with the shuttle vector. Since the shuttle vector contains T-DNA parts which are also present in the T-region of the Ti plasmid a double crossing-over between the homologous parts of both T-regions is forced. In this way the new genes are incorporated into the T-region of the intact Ti plasmid.

Existing procedures for the site directed mutation of Ti plasmids are described by Leemans et al, The EMBO 1, 147—152 (1982); Matzke et al, J. Mol. Appl. Genet. 1, 39—49 (1981); vide for the general principle, on which these techniques are based, Ruvkun et al, Nature (London) 289, 85—88 (1981). The last step of the Ti plasmid mutation is always performed in *Agrobacterium* itself, because the host range of Ti plasmids is restricted to *Rhizobiaceae*. After a cloned fragment of the Ti plasmid in *E. coli* has been mutated for instance by insertion of a transposon, the mutated fragment is subcloned on a vector with a broad host range and transferred into a Ti plasmid containing *Agrobacterium* strain. Herein the inserted DNA is incorporated by homologous recombination via double crossing-over into the Ti plasmid, whereupon either the plasmid with a broad host range is destroyed by means of an incompatible plasmid or the Ti plasmid is transferred to another *Agrobacterium* by conjugation. By investigation of the transconjugants it is checked whether the correct mutation of the Ti plasmid has taken place.

These known procedures are rather laborious and give technical problems, which could be avoided if the site directed mutation of the Ti plasmid itself could directly be performed in *E. coli*. However, the Ti plasmid is lacking an origin of replication or a replicator which can function in *E. coli*.

## EP 0 120 515 B1

The invention of the present application relates to a process for the incorporation of foreign DNA into the genome of dicotyledonous plants comprising infecting the plants or incubating plant protoplasts with *Agrobacterium tumefaciens* bacteria containing at least one plasmid, which is derived from the cointegrate plasmid pAL969 by the incorporation of foreign DNA in the T-region of the component pTiB6 characterized in that the cointegrate plasmid with foreign DNA contains only foreign DNA between the 23 base pairs of the wild-type T-region.

Such cointegrate plasmids wherein fragments of the wild type region had been replaced by foreign DNA, were used by the inventors in a process, which process was elucidated orally during a symposium on the "Molecular genetics of the bacteria plant interaction" held in Germany at the University of Bielefeld in the autumn of 1982. This paper has been published in July 1983 in a book with the same title, edited by A. Pühler.

With the process according to the present invention, a T-region with only foreign DNA between the 23 base pairs of the wild type T-region is incorporated into the genome of dicotyledonous plants by infecting such plants or incubating plant protoplasts with *Agrobacterium tumefaciens* bacteria containing at least one plasmid, which is derived from the cointegrate plasmid pAL969 by the incorporation of only foreign DNA in the T-region of the component pTiB6. The cointegrate plasmid is a stable cointegrate plasmid, obtained from a Ti plasmid (pTiB6) and an antibiotic resistance plasmid having a broad host range (R772). Cointegrate plasmids are obtained by mobilisation of the octopine Ti plasmid pTiB6 with the *Inc. P-1* type plasmid R772, as described by Hooykaas et al., Plasmid 4, 64—75 (1980). Thanks to the broad host range of the R772 component and cointegrates can replicate both in *A. tumefaciens* and in *E. coli* but mostly they are not stable; during transfer of *A. tumefaciens* to *E. coli* dissociation occurs, whereupon the Ti component of the cointegrate gets lost. However, the efforts have been successful to isolate a cointegrate plasmid which is stable in both types of bacteria: the R772::pTiB6 cointegrate plasmid pAL969, the existence of which was disclosed by Hille et al, Plasmid 7, 107—118 (1982).

This stable cointegrate plasmid opens the possibility to follow a new process in which all the steps needed for incorporating new genes into the T-region of the intact Ti plasmid are carried out in *E. coli* whereupon the cointegrate plasmid with the manipulated T-region is transferred into an *A. tumefaciens* without a Ti plasmid of its own. *Agrobacterium* strains which contain such a cointegrate plasmid are capable of inducing tumours on various types of plants or more in general of incorporating foreign DNA into chromosomes of dicotyledonous plants, such as tomato, tobacco, petunia, potato, sugarbeet, sunflower, leguminous plants, and the like.

The *Agrobacterium tumefaciens* bacteria to be used in the process according to the invention are obtained by combining a vector known *per se* for use in *Escherichia coli* provided with a T-region in which foreign DNA is incorporated, in *E. coli* as a host with the cointegrate plasmid pAL969 or a cointegrate plasmid derived therefrom by incorporation of foreign DNA in the T-region of the Ti component and transferring the cointegrate plasmid, with the foreign DNA provided by the vector incorporated in the T-region of the Ti component of the cointegrate plasmid by double crossing-over to an *A. tumefaciens* which does not itself carry a plasmid belonging to the same incompatibility groups as the two different components of the R77213 Ti cointegrate.

The result of the process of the invention is a plant or a plant cell with modified properties compared with the properties of the original plant c.q. plant cell. In this way it is possible to produce improved species of cultures, which for instance are better resistant to herbicides. Also it is possible to realize a bioreactor for fermentation of plant cells, optionally immobilised thereupon, which produce a specific desirable product, for instance, an enzyme, or a secondary metabolite of the plant cell, in large quantities.

The process according to the invention therefore offers the possibility to manufacture mutants of higher plants having well defined genetically improved resp. modified properties in an otherwise unchanged background. As already remarked before this is vital to the plant breeding industry, the more so as from the tissue lines which are obtained with application of the process according to the invention regenerants can be obtained at an early stage after transformation.

*E. coli* has a much higher rate of growth than *A. tumefaciens*, whilst many mutants are available and special cloning carriers, such as cosmids and vectors in which gene activation can occur.

The procedure according to the invention does not require shuttle vectors with a broad host range, which often are too big for recombinant DNA activities and often do not have the correction restriction enzyme sites for insertion of the T-region. In the procedure according to the invention in *E. coli* the well-known and usable small vectors (specific for *E. coli*) are used. Such a vector with the T-region, in which new genes have been incorporated, is combined in *E. coli* with the stable R::Ti cointegrate and select, via double crossing-over, those R:Ti derivatives in which the new genes are incorporated into the T-region of the Ti component of the cointegrate. As already described before, the manipulated R::Ti cointegrate is subsequently transferred to *A. tumefaciens*.

It seems that the procedure can be simplified by making use of PolA<sub>ts</sub> strains (*ts*=temperature sensitive). In such strains most of the vectors (plasmids) developed for *E. coli*, which are derived from the C 1E1 plasmid, can replicate at 32°C, but not at 42°C, though other plasmids, such as the cointegrate plasmid pAL969 are maintained at both temperatures. By a simple selection, at for instance a marker for antibiotic resistance at 42°C one would directly obtain the strains which only carry the site directed mutation, e.g. Insertion of foreign DNA, in the cointegrate plasmid.

## EP 0 120 515 B1

An *E. coli* strain, with in it the stable cointegrate plasmid pAL969, has been deposited on February 24, 1983 and available at the Centraalbureau voor Schimmelcultures (CBS) at Baarn, the Netherlands under No. CBS 190.83.

The invention is illustrated with the aid of the drawing in which:

- 5 Fig. 1 shows a physical map of the plasmid R772;
- Fig. 2 shows a physical map of the plasmid pRL246;
- Fig. 3 shows a physical map of the cointegrate plasmid pAL969;
- Fig. 4 illustrates in outline a model experiment for site directed mutagenesis of R772;
- Fig. 5 shows in outline the procedure according to the invention for the incorporation of a foreign gene
- 10 into the T-region of the Ti plasmid of *A. tumefaciens* and into the genome of dicotyledonous plants;
- Fig. 6 shows in outline an octopine Ti plasmid and
- Fig. 7 shows in outline the structure of normal T-DNA and of manipulated "artificial" T-DNA, as incorporated in the plant genome, as well as with the aid of a description of experiments carried out.

The illustration is subdivided into:

- 15 A. construction of a physical map of the stable cointegrate plasmid pAL969;
- B. model experiment for site directed mutation of R772.

Finally there is an example of the process according to the invention where a site directed mutation of the T-region was carried in the Ti component of the cointegrate plasmid pAL969 and the phenotype of the mutation was examined with divers plant species.

20 The strains and plasmids used are listed in the following table A.

TABLE A  
Bacterium strains and plasmids used

	Relevant phenotype		Source
<i>E. coli</i>			
Strains			
30	KMBL1164	Pro <sup>-</sup> , Thi <sup>-</sup>	Van de Putte
	KMBL1001	—	Van de Putte
<i>A. tumefaciens</i>			
<i>Plasmids</i>			
35	LBA 937	Rif <sup>r</sup> , Nar <sup>r</sup>	R772, pTIB6 Hooykaas et al. Plasmid 4, 64—75 (1980)
	LBA973	Gen <sup>r</sup> , Nov <sup>r</sup>	pAL969 Hooykaas
	LBA1831	Rif <sup>r</sup> , Nal <sup>r</sup>	pAL1831 Described herein
<i>Plasmids</i>			
40	R772	Km <sup>r</sup>	Hedges
	pAL969	Km <sup>r</sup>	Hooykaas
	pAL1831	Km <sup>r</sup> Ap <sup>r</sup> , Cm <sup>r</sup>	Described herein
	pRAL3501	Te <sup>r</sup> , Cm <sup>r</sup>	Described herein
45	pRL220	Tc <sup>r</sup> , Cm <sup>r</sup> , Ap <sup>r</sup> , Sm <sup>r</sup>	Hille and Schilperoort, Plasmid 6, 30—362 (1981)
	pRL220	Tc <sup>r</sup> , Ap <sup>r</sup> , Cm <sup>r</sup>	Described herein

Clones derived from R772					
Plasmid	Restriction fragment	Vector	Relevant phenotype	Source	
55	pRL231	HindIII-4	pTR262	Tc <sup>r</sup>	Described herein
	pRL232	HindIII-3	pTR262	Tc <sup>r</sup>	Described herein
	pRL233	HindIII-3+4	pTR262	Tc <sup>r</sup> , Km <sup>r</sup>	Described herein
	pRL236	EcoRI-1+2	—	Km <sup>r</sup> , Inc-P	Described herein
	pRL237	EcoRI-2	pBR322	Ap <sup>r</sup> , Tc <sup>r</sup> , Km <sup>r</sup>	Described herein
60	pRL238	HindIII-1+2	pTR262	Tc <sup>r</sup> , Inc-P	Described herein
	pRL247	PstI-6	pBR325	Cm <sup>r</sup> , Tc <sup>r</sup>	Described herein
	pRL248	PstI-3	pBR325	Cm <sup>r</sup> , Tc <sup>r</sup>	Described herein
	pRL246	pBR322::IS70	—	Ap <sup>r</sup> , Tc <sup>r</sup>	Described herein
65	pRL239	—	—	Km <sup>r</sup> , Ap <sup>r</sup> , Cm <sup>r</sup> , Inc-P	Described herein

## EP 0 120 515 B1

The conjugations were performed in conformity with the specification by Hille et al, Plasmid 7, 107—118 (1982).

The plasmid isolation occurred for *E. coli* as described by Birnboim and Doly, Nucl. Ac. Res. 7, 1513—1523 (1979) and for *A. tumefaciens* as described by Koekman et al, Plasmid 4, 184—195 (1980).

5 Cleavage with restriction endonucleases, agarose gel electrophoresis, Southern blotting and DNA-DNA filter hybridisation were performed as described by Prakash et al, J. Bacteriol. 145, 1129—1136 (1981).

The ligation of restriction fragments was carried out in 6.5 mM MgCl<sub>2</sub>; 60 mM Tris-HCl pH 7.6; 10 mM dithiothreitol and 0.4 mM ATP for 20 hours at 14°C. The DNA concentration in the ligation mixture was usually about 100 µg per ml, with an excess of five times of the DNA to be cloned with regard to the vector DNA. After ligation the mixture was immediately used for transformation.

10 Transformation of *E. coli* cells occurred by means of the CaCl<sub>2</sub> method described by Cohen et al. Proc. Nat. Acad. Sci. 69, 2110—2114 (1972).

### A. Construction of a physical map of the stable cointegrate plasmid pAL969

15 In experiments described by Hooykaas et al, Plasmid 4, 64—75 (1980), in which an octopine Ti plasmid pTiB6) was mobilized with the *Inc.P-1* type plasmid R772 with a broad host range, a particular R772::Ti cointegrate plasmid (pAL969) was obtained. When strains which contain this plasmid were used as donor in further crossings, 100% cotransfer of R772 and Ti plasmid markers could be shown, i.e. 100% cotransfer in case of transfer from *E. coli* to *A. tumefaciens* and v.v.. The R::Ti cointegrate was stable in both *E. coli* and *A. tumefaciens* and so did not desintegrate into the composite plasmids. In order to obtain insight into the stability of this cointegrate plasmid observed a physical map of the plasmid was constructed. For that purpose first a map of the *Inc.P-1* type plasmid R772 was composed (Fig. 1). Thereupon a transposition element was identified and isolated from R772, (Fig. 2). Finally, a physical map for the plasmid pAL969 was composed, in which more or less intact copies of the transposition element are indicated (Fig. 3).

20 10 Different restriction endonucleases were tested with R772 DNA. It appeared that three of them, to wit BglII, KpnI and Bal, could not digest the plasmid, whilst the restriction endonuclease *BamHI* cut the plasmid open at one site. The other restriction enzymes, to wit *HpaI*, *SaI*, *SmaI*, *HindIII*, *EcoRI* and *PstI* cut the plasmid at various sites. From table B the number of recognition sites and fragment lengths can be read:

TABLE B  
Length of restriction endonucleases fragments of R772 (in Mdalton).

Enzyme	BamHI	HpaI	SaI	SmaI	HindIII	EcoRI	PstI
fragment							
1	40.5	23.0	13.0	20.4	19.8	19.1	18.3
2		16.1	11.6	12.5	10.7	6.4	9.0
3		1.4	8.9	4.4	6.0	6.4	4.7
4			7.0	2.7	4.0	5.8	4.4
				0.5		1.8	2.4
						1.0	1.7

45 The size of the R772 DNA is 40.5 Mdalton. The unique *BamHI* place was selected as origin (reference point) on the map. The order of the fragments could not yet be established unambiguously after double digestions. That is why individual *HindIII* and *SaI* restriction fragments of R772 were isolated from the gel, labelled *in vitro* with <sup>32</sup>P, and hybridised on blots which contain R772 DNA, which was digested with all restriction enzymes investigated. From the position of hybridising fragments, observed on autoradiograms, a provisional circular map of R772 could be constructed. As many restriction endonuclease recognition sites were positioned so close to each other that the order could not yet be established unambiguously, particular restriction fragments of R772 were cloned on multicopy plasmids. The *PstI* fragments 6 and 3 were cloned on pBR325, and the *HindIII* fragments 4, 3, 4+3 and 1+2 were cloned on the vector pTR262 in which gene activation can occur after insertion (described by Roberts et al, Gene 12, 123—127 (1980)). By using these clones in restriction endonuclease analysis most of the recognition sites could be mapped accurately. Only the *EcoRI* fragments 5 and 6 and the *PstI* fragments 4 and 5 could not be arranged, because they are neighbours and do not contain restriction sites of the other restriction enzymes (vide fig. 1).

60 The cloning experiments also gave information on the position of particular genetic properties, that was not yet known for plasmid R772. From the *HindIII* cloning experiment on pTR262 it turned out that neither *HindIII* fragment 4 nor *HindIII* fragment 3 contained an intact kanamycin resistance Km<sup>r</sup>-locus (the only marker for antibiotic resistance of the plasmid R772), whilst in case of combined cloning of these *HindIII* fragments 3+4 as one segment with maintenance of the original orientation kanamycin resistance was found. This seemed to be an indication that the Km<sup>r</sup>-locus overlaps the *HindIII* recognition site in this segment consisting of the fragments 3 and 4. This was confirmed by cloning of *EcoRI* fragments of R772

EP 0 120 515 B1

and pBR322, in that *EcoRI* fragment 2 appeared to contain the  $Km^r$ -locus. In these *EcoRI* cloning experiments also a plasmid was found which only contained the  $Km^r$  determinant and no pBR322 markers. This plasmid (pRL236) appeared to consist of the *EcoRI* fragments 1 and 2 of R772 which is an indication that these two fragments together contained all information required for autonomous replication. As this plasmid pRL236 appeared to be transfer deficient, *tra* functions must be in the region of the *EcoRI* fragments 3, 4, 5 or 6. A clone pHL238 consisting of pTR262 and the *HindIII* fragments 1 and 2 of R772 appeared to be  $Tra^+$  and be able to replicate in *Agrobacterium*. As the pTR262 replicator does not work in *Agrobacterium* consequently the *HindIII* fragments 1 and 2 of R772 must contain all the information required for auto-transfer and autonomous replication. The replication and incompatibility functions of R772 must therefore be in *Hind* fragment 1.

(Abbreviations used: *tra* for functions which are required for autotransfer by conjugation; *ori* for origin of replication; *inc* for incompatibility functions).

In the article by Hooykaas et al, Plasmid 4, (64—75 (1980) earlier mentioned it is indicated that mobilised Ti plasmids of *A. tumefaciens* carry an insertion sequence or transposon which originates from the mobilising plasmid. If it is assumed that mobilisation proceeds via cointegrate formation as a result of transposition, the presence of two directly repeated copies of a transposable element in an unstable intermediary product is expected. The instability is the result of homologous recombination between the two intact copies of the transposable element, in consequence of which the cointegrate would desintegrate in its components. In order to be able to understand the stability of the cointegrate plasmid pAL969, the position and the structure of copies of the transposable element have been investigated.

A transposable element identified for R772 was isolated on pBR322. The plasmid in question (pRL246) was analysed, and it appeared that the transposable element did not contain the antibiotic resistance marker of R772 ( $Km^r$ ), so that the transposable element is an insertion sequence (called IS70). Homoduplex analysis of plasmid pRL246 revealed that IS70 carried short inverted repeats at its extremities having a length of about 50 base pairs (not shown). By means of restriction of endonucleases the 2,5 Mdalton long IS70 was mapped on pBR322 (Fig. 2). By means of this map the position of IS70 in R772 could be determined accurately (vide Fig. 1).

The R772::Ti cointegrate plasmid pAL969 the position of cointegration between R772 and the Ti plasmid was determined by means of six different restriction endonucleases. The results are listed in the following table C.

TABLE C  
Position of cointegration in R772 and in pTiB6 for the R772::pTiB6 cointegrate

Enzyme	Cointegration took place in	
	Fragment R772	Fragment pTiB6
<i>BamHI</i>	1	15
<i>SmaI</i>	4	5
<i>HpaI</i>	1	10
<i>HindIII</i>	4	28A
<i>EcoRI</i>	2	16
<i>PstI</i>	3	*

\* not determined

From these results it could be derived that the position of cointegration on R772 is present in a 1.5 Mdalton fragment (the part which overlaps *SmaI* fragment 4 and *PstI* fragment 3, vide Fig. 1) and on the Ti plasmid is present in a 0.8 Mdalton fragment (*EcoRI* fragment 16 and *HindIII* fragment 28A). When comparing the 1.5 Mdalton fragment on R772, in which cointegration had taken place, with the map of R772 it is apparent that this fragment carries part of the insertion sequence IS70, which leads one to assume that the cointegration indeed occurred via IS70.

When the cointegrate plasmid pAL969 would be cleaved with a restriction enzyme which does not have a recognition site in IS70, one would expect to find two fragments, which show sequence homology with IS70, to wit the two R772::Ti fusion fragments; in case of cutting with a restriction enzyme, which has one recognition place in IS70, one would expect to find four fragments with sequence homology with IS70; taken all this together assuming that the cointegrate plasmid contains two complete copies of IS70.

In practice this appeared not to be correct. The plasmid pBR322::IS70 (pRL246) was labelled *in vitro* and hybridised on blots which contain separate pAL969 DNA digested with different restriction enzymes. In cases in which a restriction enzyme was used which does not have a recognition site in IS70 (*EcoRI*, *HpaI*), as expected, two different bands were observed on the autoradiograms. When using the restriction enzyme *SmaI*, which has one recognition site in IS70, however, not four but only three bands were observed.

It appears from the results that the cointegration of R772 and the Ti plasmid took place via IS70,

## EP 0 120 515 B1

because the IS70 appeared to be present in duplicate. Apparently there only is one intact copy of IS70 whereas the other fragment is a deleted IS70. The length of the deleted IS70 is estimated to be at most 0.5 Mdalton. Furthermore, it can be concluded from the sum of the lengths of the fusion fragments of the cointegrate that a small piece of DNA of at most 0.5 Mdalton in the pTi component must have been deleted, although none of the restriction places investigated got lost.

The map of pAL969 with indication of IS70, the deleted IS70 and the Km<sup>r</sup> locus constructed on the basis of these data is shown in Fig. 3. Fragments originating from R772 are provided with an asterisk.

The remarkable stability of pAL969 can now be explained by accepting that the length of the incomplete second copy of IS70 is not sufficient to make possible an efficient homologous recombination, which would lead to dissociation of the cointegrate into its composite plasmid.

### B. Model experiment for site directed mutation of R772

A model experiment was designed for examining the application of the stable cointegrate pAL969 for site directed mutagenesis in *E. coli*. Because of the relatively small size of R772 (40.5 Mdalton) modifications in the restriction patterns of a mutated R772 plasmid could be interpreted more easily than with the cointegrate plasmid, which has a size of 162 Mdalton. That is why first a site directed mutation was introduced in R772, characterised in it and only then introduced into the plasmid pAL969.

The *Hind*III fragment 3 of R772 (length 6 Mdalton) was cloned on the vector pTR262 in which gene activation can occur after insertion. This fragment does not contain functions which are essential for auto-transfer or autonomous replication of R772. The resulting plasmid pRL232 has 3 *Eco*RI recognition sites which are all of them present in the cloned fragment: the vector part (pTR262) has no *Eco*RI sites. The two small internal *Eco*RI fragments of pRL232 (lengths resp. 1.8 and 1.0 Mdalton) were removed and replaced by an *Eco*RI fragment (total length 5.8 Mdalton) of the plasmid pRL220, which fragment contained ampicillin (Ap) and chloroamphenicol (Cm) resistance determinants. Thus a plasmid pRL234 was obtained which had Ap, Cm and Tc (tetracycline) resistance loci (vide Fig. 4a). On both sides of the Ap<sup>r</sup>Cm<sup>r</sup> fragment there was a segment, about 1.5 Mdalton long, with sequence homology to R772 (thick lines in Fig. 4).

R772 and pRL234 were combined in one bacterial cell (KMBL1164) in order to effect transfer of the Ap<sup>r</sup>Cm<sup>r</sup> segment to R772 via homologous recombination (vide Fig. 4a). This strain was then used as a donor in a crossing with KMBL100 (vide Fig. 4b). The transfer of *inc*I, plasmid R772 was high; about 1% of the recipient bacteria received this plasmid. In earlier experiments it was found that R772 mobilises the plasmid pBR322 with a frequency of 10<sup>-5</sup> per transferred R772 (via IS70 of R772). Consequently it was expected that R772 would mobilise also the plasmid pRL234 via IS70 with a frequency of about 10<sup>-5</sup>. Actually, however, a transfer value for the Ap<sup>r</sup> determinant of 10<sup>-2</sup> per transferred R772 was observed, much higher than expected for mobilisation by means of a transposition occurrence. The high transfer frequency is presumably caused by the homology between pRL234 and R772.

For further analysis 22 Ap<sup>r</sup> colonies were selected; 14 thereof were Ap<sup>r</sup>, Cm<sup>r</sup>, Km<sup>r</sup>, Tc<sup>r</sup> and 8 thereof were Ap<sup>r</sup>, Cm<sup>r</sup>, Km<sup>r</sup> and Tc<sup>r</sup>. The set of 14 colonies showed expression of all markers both of R772 and of pRL234, from which it appeared that the complete pRL234 was mobilised (mobilisation frequency 6.5 × 10<sup>-3</sup> per transferred R772). The set of 8 colonies, however, carried the R772 marker (Km<sup>r</sup>) and the Ap<sup>r</sup> and Cm<sup>r</sup> markers of the mutated *Hind*III fragment 3 of R772, but not the marker of the vector plasmid (Tc<sup>r</sup>). These 8 colonies therefore seemed to have received the site directed mutation through insertion of the Ap<sup>r</sup>Cm<sup>r</sup> segment (replacement frequency 3.5 × 10<sup>-3</sup> per transferred R772). Plasmid DNA was isolated from three independent colonies and analysed via agarose gels: for all three only one plasmid of the same size was observed. The pattern of fragments obtained by digestion with *Hind*III was identical for these plasmids; the fragment 4 typical of a *Hind*III digestion of R772 had disappeared, whereas two new fragments were visible. These two new fragments were identical to the mutated *Hind*III fragment 3 or R772 in pRL234. In the plasmid pRL239 derived from R772 (vide Fig. 4c) no band of the vector plasmid pTR262 was found. So R772 was indeed mutated by homologous recombination.

The same mutation was introduced into the cointegrate plasmid pAL969 in a similar manner. The results essentially corresponded to those obtained when using R772 and transferring a thus mutated R772::Ti cointegrate plasmid in *A. tumefaciens* bacteria and infecting plants therewith caused formation of normal tumours. This is in conformity with expectations, because the mutation was not localised in the Ti component of the cointegrate plasmid.

### Example

The suitability of the procedure described for site directed mutagenesis of the T-region of the Ti component of the cointegrate plasmid pAL969 was investigated by cloning a fragment of the T-region (*Eco*RI fragment 7, vide Fig. 3) on the vector pACYC184. The plasmid pRAL3501 received contained two *Pst*I recognition sites. The 0.5 Mdalton long *Pst*I fragment was replaced by a 2.7 Mdalton long fragment with a Cm<sup>r</sup> determinant, which fragment originated from the plasmid pRL220. On both sides of the segment containing the Cm<sup>r</sup> determinant there were pieces of DNA having lengths of resp. 2.5 and 1.8 Mdalton, which had sequence homology with the T-region. This mutation was then introduced into the cointegrate plasmid pAL969 as described earlier. The mutation was introduced into the pAL969 with a frequency of one to three Cm<sup>r</sup> transconjugants. One mutated pAL969 plasmid, called pAL1831, was isolated and digested with different restriction endonucleases, whereupon the fragment patterns were investigated by means of



## EP 0 120 515 B1

agarose gel electrophoresis. Herein it was confirmed that the 0.5 Mdalton *Pst*I fragment of pAL969 in pAL1831 was replaced by a 2.7 Mdalton *Pst*I fragment.

When the position of the foreign 2.7 Mdalton *Pst*I fragment present in pAL1831 is replaced compared with the genetic maps of the T-region (vide Garfinkel et al, Cell 27, 143—153 (1981) and Ooms et al, Gene 14, 33—50 (1981) the mutation appears to be in the locus which causes a cytokinin like effect. Compared with the transcription map of the T-region (vide Willmitzer et al, The EMBO 1, 139—146 (1982) transcript 4 is mutated.

The cointegrate plasmid pAL1831 was transferred from *E. coli* to *A. tumefaciens*, whereupon for one of the transconjugants the tumor-inducing capacity on different plant species was studied. Unlike tumours induced by wild type octopine strains, the small tumours, which are induced by pAL1831 containing *Agrobacterium* bacteria on tobacco, developed roots. Also on *Kalanchoë* stems more than a normal root formation from tumours was observed. On tomatoes only small tumours were formed. These observations were in full agreement with the known phenotype of such mutations.

The procedure followed is represented in outline in Fig. 5.

Fig. 6 gives a picture of an octopine Ti plasmid, subdivided in a part responsible for tumour induction and a part responsible for the catabolism of octopine (octopine catabolism gene Occ) and arginine (arginine catabolism gene Arc). Tra, Inc and Rep are functions for resp. conjugation, incompatibility and replication. Aux, Cyt and Ocs are loci for resp. auxine and cytokine-like effects and octopine synthesis in the tumour cell.

Fig. 7 shows in larger detail the structure of the T-region of octopine Ti plasmids, after incorporation in the plant genome. At the extremities of the T-region there is a special base sequence of about 23 base pairs (bp), which is involved in the transfer and integration of T-DNA in the plant genome. Also, an "artificial" T-DNA, incorporated in the plant genome, is shown which contains one or more desirable genes and a marker gene for the selection of transformants. In order to make expression of these genes in the plant cell possible, special base sequences are present, including a plant promoter (Pp) as a starting place for the transcription in RNA(→), which see to the regulation of the gene expression in eucaryotes.

### Claim

A process for the incorporation of foreign DNA into the genome of dicotyledonous plants comprising infecting the plants or incubating plant protoplasts with *Agrobacterium tumefaciens* bacteria containing at least one plasmid which is derived from the cointegrate plasmid pAL969 by the incorporation of foreign DNA in the T-region of the component pTiB6 characterized in that the cointegrate plasmid with foreign DNA contains only foreign DNA between the 23 base pairs of the wild-type T-region.

### Patentanspruch

Ein Verfahren zum Einbauen fremder DNS in das Genom von zweikeimblättrigen Pflanzen, durch Pflanze zu infizieren oder Pflanzenprotoplaste zu inkubieren mit *Agrobacterium tumefaciens* Bakterien, die wenigstens ein Plasmid enthalten, das von dem Kointegratplasmid pAL969 durch den Einbau fremder DNS in das T-Gebiet der Komponente pTiB6 abgeleitet ist, dadurch gekennzeichnet, dass das Kointegratplasmid mit fremder DNS nur fremde DNS zwischen den 23 Basis-Paaren des Wildtyp T-Gebiets enthält.

### Revendication

Procédé pour l'incorporation d'ADN étranger dans le génome de plantes dicotylédones, qui comprend l'infection des plantes ou l'incubation des protoplastes de la plante avec des bactéries *Agrobacterium tumefaciens* contenant au moins un plasmide dérivé du plasmide cointégré pAL969 par incorporation d'ADN étranger dans la région-T du composant pTiB6 caractérisé en ce que le plasmide cointégré avec un ADN étranger ne contient que l'ADN étranger entre les 23 paires de base de la région-T du type sauvage.

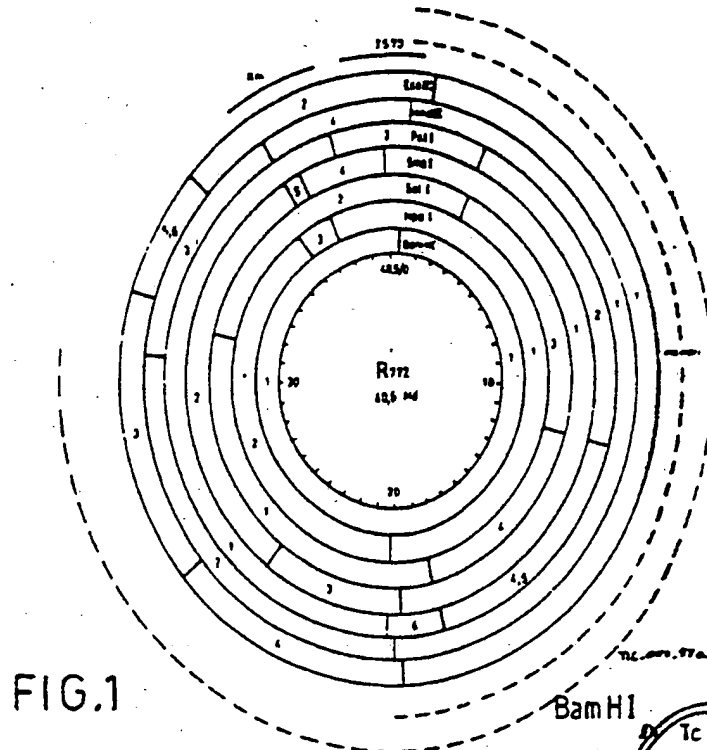

FIG. 1

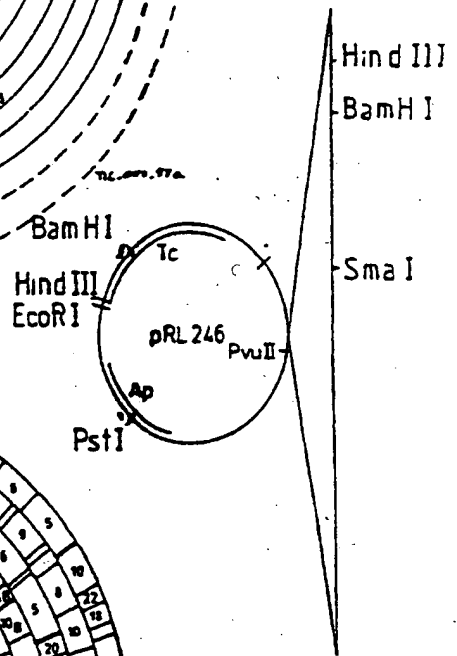

FIG. 2

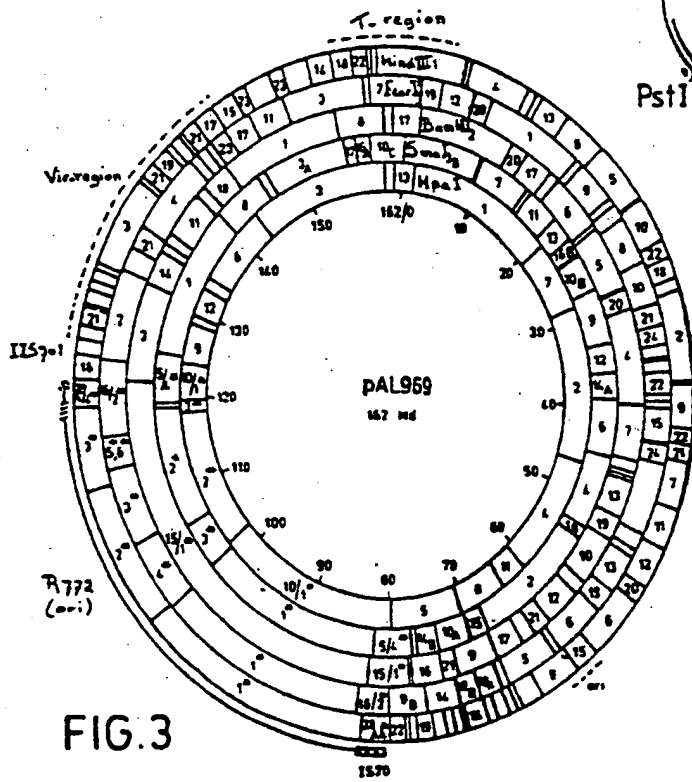

FIG. 3

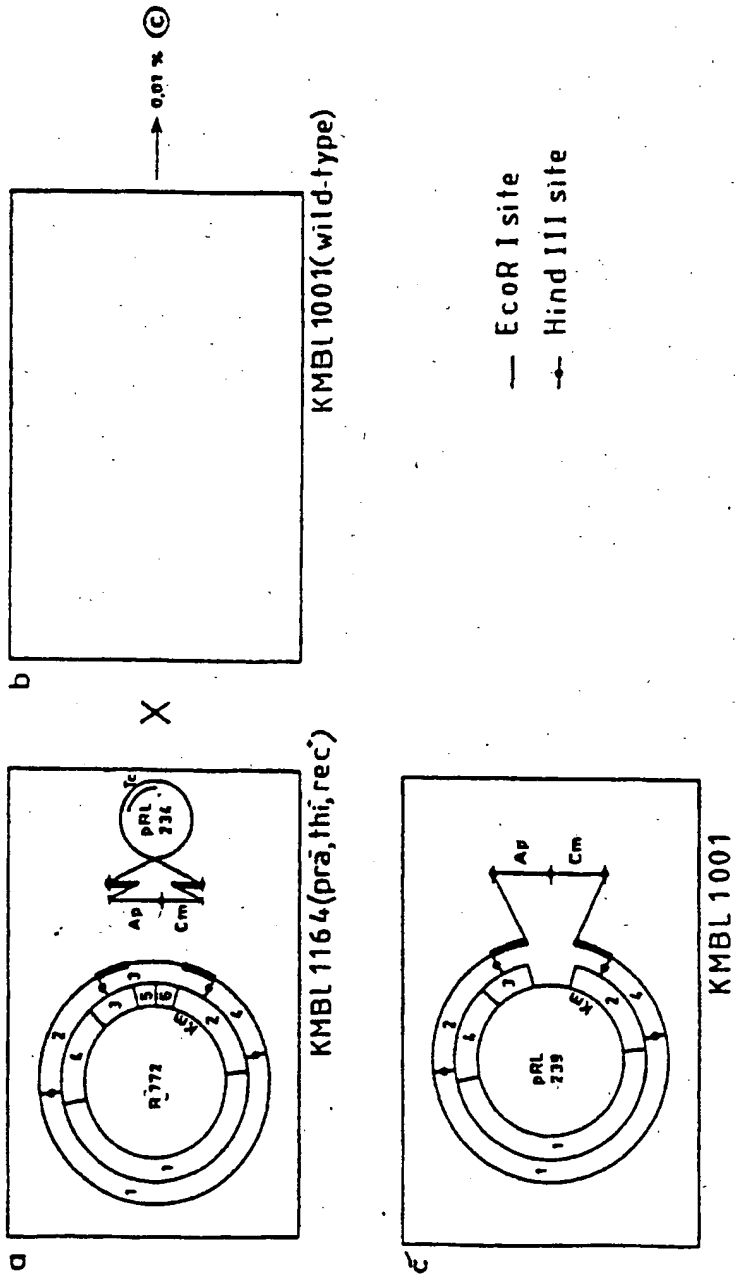

FIG. 4

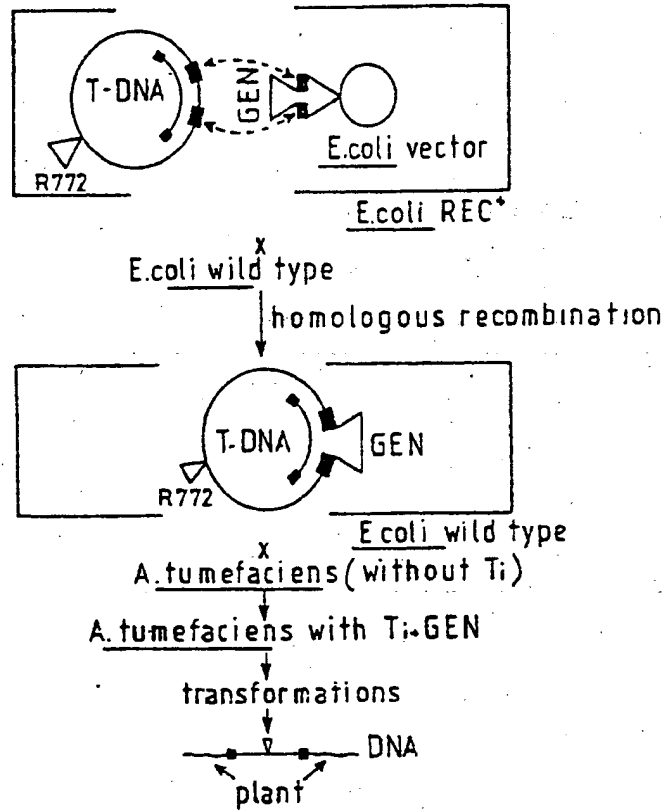

FIG.5

